

Instructions

Ideal for Airplanes, Cars, Boats and Helicopters

Assemble the Prop Balancer as shown in the illustration. The small (8-32) knurl nuts are used to lock the posts to the base and the larger (10-32) knurl nuts are used to adjust the height of the balance wheel housings.

The Prop Balancer is completely adjustable for height and length and can be used in two different configurations. To balance most props up to 12" in diameter, use Fig. A configuration. For larger props and for helicopter rotor heads, use the balancer as shown in Fig. B. Place the balancer at the edge of your work bench and hold with a clamp or weight.

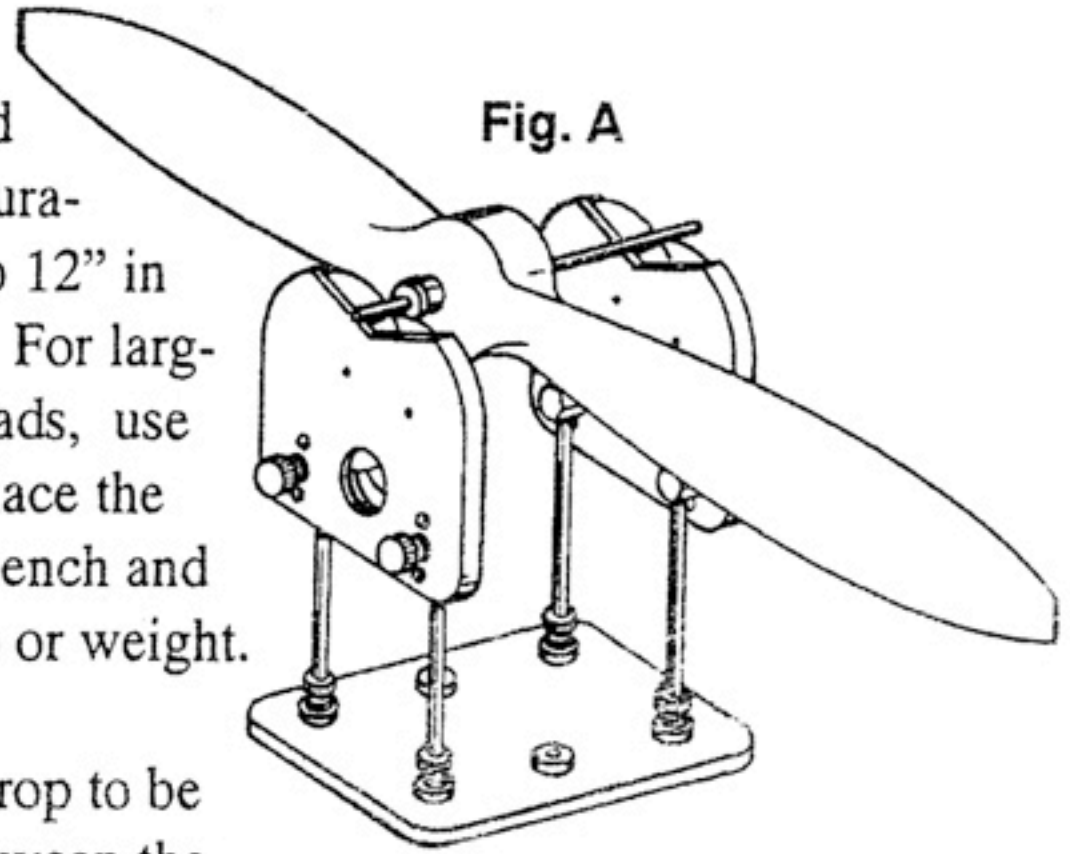

Fig. A

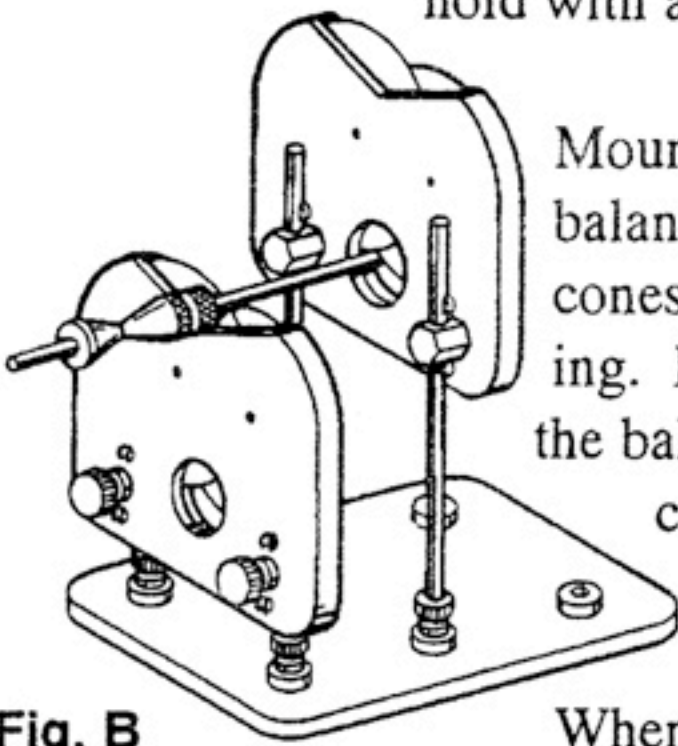
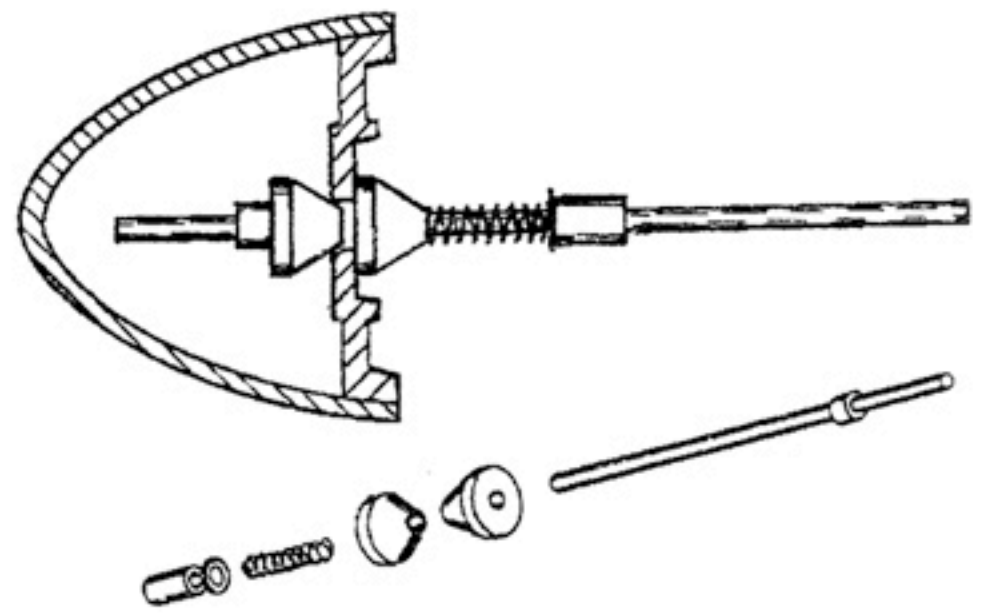
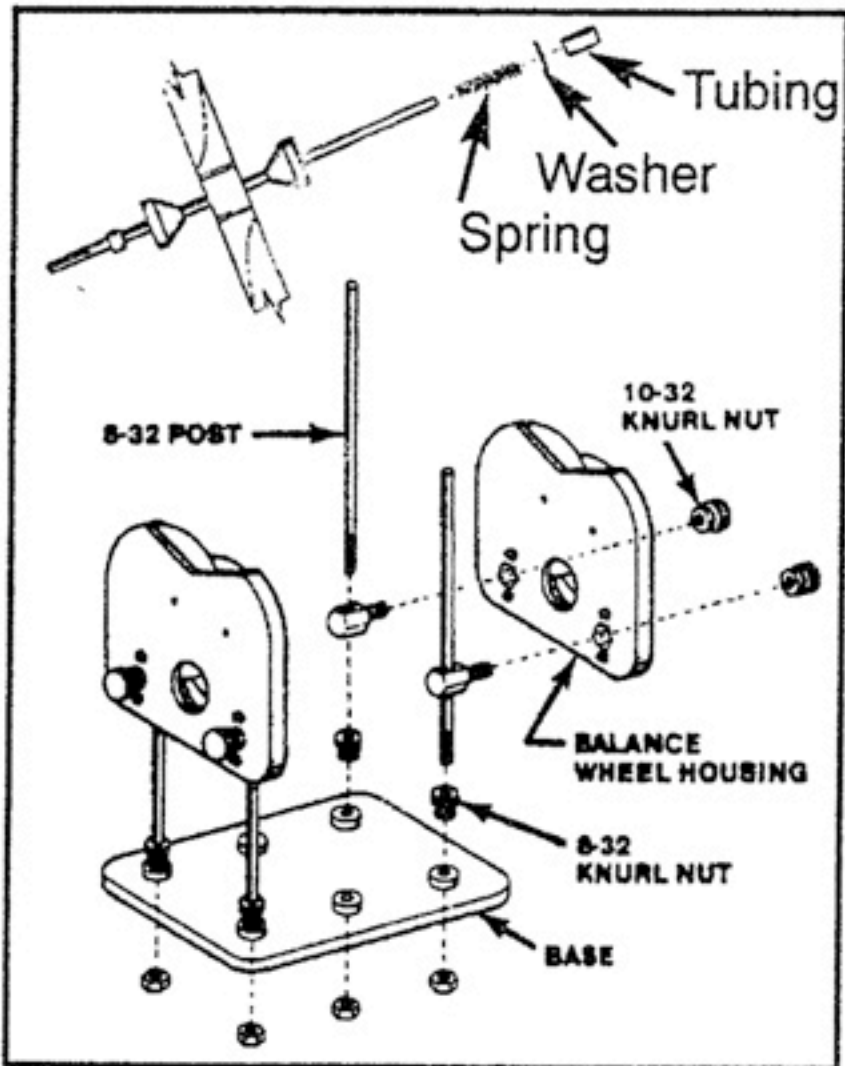

Fig. B

Mount the prop to be balanced between the cones and lock into position with the spring and tubing. Now place the balancing shaft on the wheels of the balancer. The prop will rotate back and forth indicating one side is heavy. When the prop stops, the heavy side will be at the bottom. Remove material from the heavy side by sanding or carving.

When placed back on the balancer, a perfectly balanced prop will remain stationary in any position.



Adjustable locking cones for precise balancing of props and helicopter blades.

WARNING: This product contains lead, a chemical known to the State of California to cause cancer and birth defects and other reproductive harm.

Made in U.S.A.

Du-Bro Products, Inc.
P.O. Box 815, 480 Bonner Road
Wauconda, IL 60084
<http://www.dubro.com>

